

LUBRIFICAZIONE

LUBRICATION

A GRAISSER



**ALTA RESISTENZA**

SERIE **RM..S**

**HEAVY DUTY**

SERIES **RM..S**

**HAUTE RESISTANCE**

SERIE **RM..S**

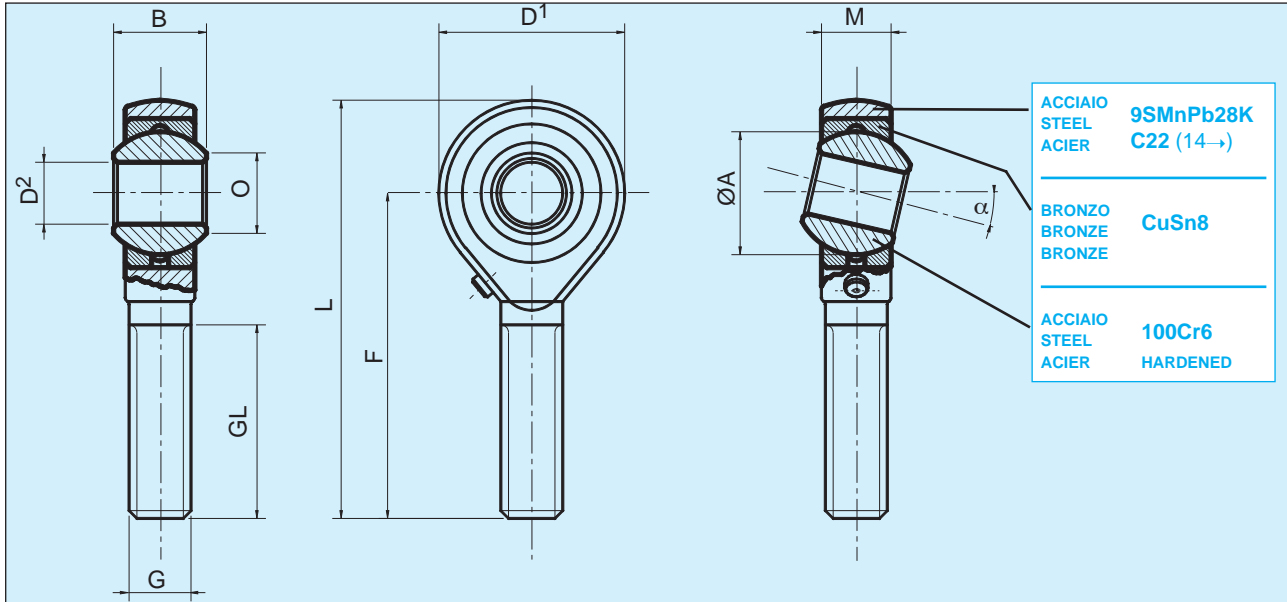

TIPO/TYPE	D <sup>2</sup>	B	M	O	D <sup>1</sup>	F	L	GL	ØA	FILETTATURA G THREAD G FILETAGE G	STATIC MAX. Co-daN RADIAL	AXIAL	α°	PESO WEIGHT POIDS
<b>RM 2 S</b>	2	4,8	3,6	3,6	9	18	24,5	9	6,000	M 2x0,5	60	27	15°	2 g
<b>RM 3 S</b>	3	6	4,5	5,1	14	27	33	15	7,937	M 3x0,5	150	67	13°	6 g
<b>RM 5 S</b>	5	8	6	7,7	18	33	42	20	11,112	M 5x0,8	430	190	13°	13 g
<b>RM 6 S</b>	6	9	6,75	8,9	20	36	46	22	12,700	M 6x1	600	270	13°	20 g
<b>RM 8 S</b>	8	12	9	10,4	24	42	54	25	15,875	M 8x1,25	1100	495	13°	33 g
<b>RM 10 S</b>	10	14	10,5	12,9	28	48	62	29	19,050	M10x1,5	1740	780	13°	56 g
<b>RM 12 S</b>	12	16	12	15,4	32	54	70	33	22,225	M12x1,75	2350	1057	13°	87 g
<b>RM 14 S</b>	14	19	13,5	16,8	36	60	78	36	25,400	M14x2	2080	935	15°	129 g
<b>RM 16 S</b>	16	21	15	19,3	42	66	87	40	28,575	M16x2	3200	1440	15°	189 g
<b>RM 18 S</b>	18	23	16,5	21,8	46	72	95	44	31,750	M18x1,5	3860	1735	15°	267 g
<b>RM 20 S</b>	20	25	18	24,3	50	78	103	47	34,925	M20x1,5	4380	1970	15°	348 g
<b>RM 22 S</b>	22	28	20	25,8	54	84	111	51	38,100	M22x1,5	5260	2360	15°	443 g
<b>RM 25 S</b>	25	31	22	29,6	60	94	124	57	42,850	M24x2	6240	2810	15°	600 g
<b>RM 30 S</b>	30	37	25	34,8	70	110	145	66	50,800	M30x2	8160	3670	15°	1030 g
<b>RM 35 S</b>	35	43	28	37,7	80	125	165	85	57,150	M36x2	10080	4530	15°	1600 g
<b>RM 40 S</b>	40	49	35	44,2	90	142	187	78	65,960	M42x2	12400	5580	15°	2550 g

**FILETTATURA:**

classe ISO-DIN 13-6h, per filettatura sinistra sigla **RML..S**.

Altri passi di filettatura pag. 3.

**LUBRIFICAZIONE:**

tramite ingrassatore sulla testa.

**GIOCO:**

radiale 0,030-0,050 mm, assiale 0,050-0,090 mm.

Gioco ristretto o allargato su richiesta.

**VARIANTI SPECIALI:**

cromatura, nickelatura chimica, etc., cfr. tabella ultima pagina.

**THREAD:**

ISO-DIN 13-6h class, for lefthand thread part name **RML..S**.

Other thread pitches, see page 3.

**LUBRICATION:**

through grease nipple fitted on the body.

**CLEARANCE:**

radial 0,030-0,050 mm, axial 0,050-0,090 mm.

Reduced or wider clearance on inquiry.

**CUSTOM FEATURES:**

chrome plating, chemical nickel plating, etc., see last page.

**FILETAGE:**

classe ISO-DIN 13-6h, pour filetage gauche dénomination **RML..S**.

Autres pas de filetage, voir page 3.

**GRAISSAGE:**

par graisseur placé sur le corps.

**JEU:**

radial 0,030-0,050 mm, axial 0,050-0,090 mm.

Jeu réduit ou agrandi sur demande.

**SERIES SPECIALES:**

chromage, nickelage chimique, etc., voir dernière page.