

LUBRIFICAZIONE

SENZA MANUTENZIONE

**EXTRA RESISTENZA**

SERIE: **RM..X**  
**RM..XE**

LUBRICATION

MAINTENANCE FREE

**EXTRA HEAVY DUTY**

SERIE: **RM..X**  
**RM..XE**

A GRAISSER

SANS ENTRETIEN

**EXTRA RESISTANCE**

SERIE: **RM..X**  
**RM..XE**

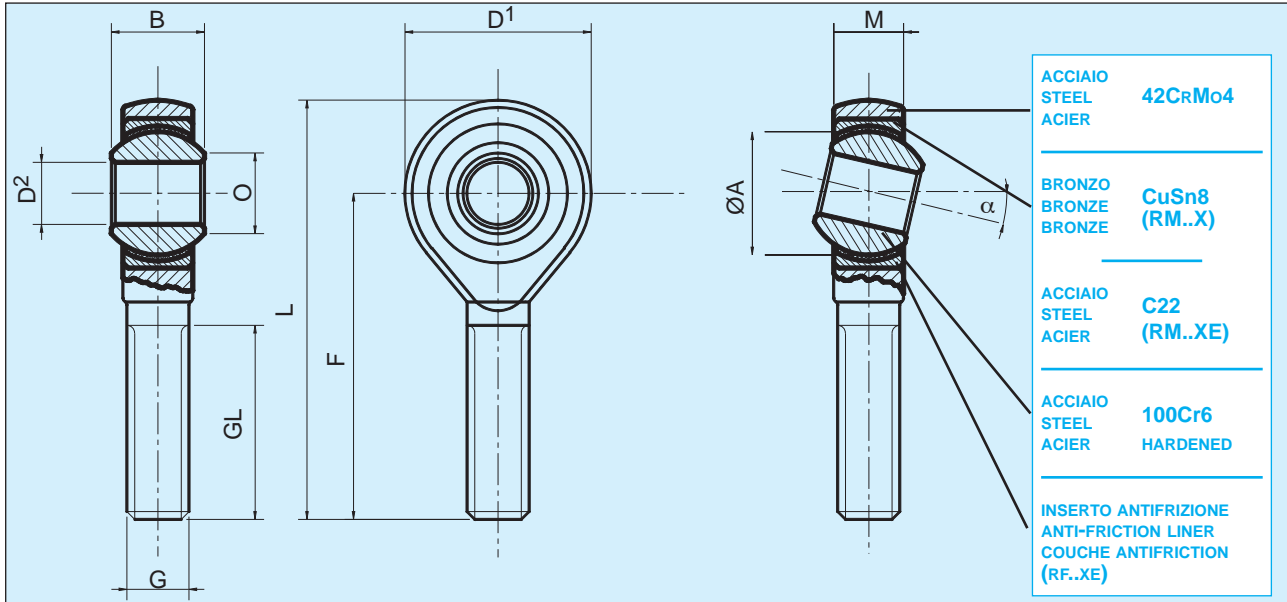

TIPO/TYPE	D <sup>2</sup>	B	M	O	D <sup>1</sup>	F	L	GL	ØA	FILETTATURA G THREAD G FILETAGE G	STATIC MAX. Co-daN RADIAL AXIAL	α°	PESO WEIGHT POIDS	
<b>RM 6 X(E)</b>	6	9	6,75	8,9	20	36	46	22	12,700	M 6x1	980	490	13°	20 g
<b>RM 8 X(E)</b>	8	12	9	10,4	24	42	54	25	15,875	M 8x1,25	1950	780	13°	33 g
<b>RM 10 X(E)</b>	10	14	10,5	12,9	28	48	62	29	19,050	M10x1,5	3140	1130	13°	56 g
<b>RM 12 X(E)</b>	12	16	12	15,4	32	54	70	33	22,225	M12x1,75	4220	1520	13°	87 g
<b>RM 14 X(E)</b>	14	19	13,5	16,8	36	60	78	36	25,400	M14x2	5690	1950	15°	129 g
<b>RM 16 X(E)</b>	16	21	15	19,3	42	66	87	40	28,575	M16x2	6720	2450	15°	189 g
<b>RM 18 X(E)</b>	18	23	16,5	21,8	46	72	95	44	31,750	M18x1,5	8140	2940	15°	267 g
<b>RM 20 X(E)</b>	20	25	18	24,3	50	78	103	47	34,925	M20x1,5	9370	3530	15°	348 g
<b>RM 22 X(E)</b>	22	28	20	25,8	54	84	111	51	38,100	M22x1,5	11380	4340	15°	443 g
<b>RM 25 X(E)</b>	25	31	22	29,6	60	94	124	57	42,850	M24x2	13540	5350	15°	600 g
<b>RM 30 X(E)</b>	30	37	25	34,8	70	110	145	66	50,800	M30x2	18440	7210	15°	1030 g
<b>RM 35 X(E)</b>	35	43	28	37,7	80	125	165	75	57,150	M36x2	23000	9500	15°	1600 g

### FILETTATURA:

classe ISO-DIN 13-6h, per filettatura sinistra sigla **RML..X(E)**.  
Altri passi di filettatura pag. 3.

### LUBRIFICAZIONE:

tipi **..X** con ingrassatore, tipi **..XE** inserto antifrizione con PTFE, senza manutenzione.

### GIOCO:

radiale 0,030-0,050 mm, assiale 0,050-0,090 mm.

Gioco ristretto o allargato su richiesta.

### VARIANTI SPECIALI:

cromatura, nickelatura chimica, etc., cfr. tabella ultima pagina.

### THREAD:

ISO-DIN 13-6h class, for lefthand thread part name **RML..X(E)**.  
Other thread pitches, see page 3.

### LUBRICATION:

**..X** units with grease nipple, **..XE** units anti-friction liner with PTFE, maintenance free.

### CLEARANCE:

radial 0,030-0,050 mm, axial 0,050-0,090 mm. Reduced or wider clearance on inquiry.

### CUSTOM FEATURES:

chrome plating, chemical nickel plating, etc., see last page.

### FILETAGE:

classe ISO-DIN 13-6h, pour filetage gauche dénomination **RML..X(E)**.  
Autres pas de filetage, voir page 3.

### GRAISSAGE:

types **..X** avec graisseur, types **..XE** ont une couche antifricion avec PTFE, sans entretien.

### JEU:

radial 0,030-0,050 mm, axial 0,050-0,090 mm. Jeu réduit ou agrandi sur demande.

### SERIES SPECIALES:

chromage, nickelage chimique, etc., voir dernière page.